

Main Features

- Wetted parts stainless steel 1.4571 (316Ti)
- Diaphragm with longitudinal starshaped profil
- Easy and fast installation

Applications

- Water & Waste water
- Energy

Description

This tongue diaphragm seals with union nut are used to protect pressure gauges from high temperatures, aggressive or corrosive fluids.

They avoid that the medium flows into the instrument, where deposits could be built and generate wrong measurements or pollution of the process.

Tongue seals have a large membrane surface in relation to the small connection size. That's why they can be used for measurement of lower pressure ranges compared to threaded seals with flush diaphragm. Tongue seals should not be used in pipes with strong flow of the medium.

Chemical seal can be mounted to mechanical pressure gauges, switches or transmitters directly or with a cooling element. The filling fluid of the measuring system has to be chosen compatible to the application.

Process connection	Union nut
Pressure ranges	0 ... 1 bar to 0 ... 1000 bar (see table below)
Body material	Stainless Steel 1.4571 (316Ti)
Diaphragm	Stainless Steel 1.4571 (316Ti)
Bottom	Stainless Steel 1.4571 (316Ti)
Union nut	Stainless Steel 1.4571 (316Ti)
Working temperature	-60...200 °C (depending on the filling fluid)
Filling fluids	LRS1: Vaseline (-15 ... +150 °C) LRS10: Vaseline (-20 ... +225 °C) Other filling fluids on request

Ordering code / Minimum pressure ranges

Code	Connection	Pressure gauges ⁽¹⁾		Transmitters ⁽²⁾	P max.
		NS 50-63 mm	NS 100-150-160 mm		
1511	G 1	0 ... 2.5 bar	0 ... 6 bar	0 ... 1 bar	1000 bar
1513	G ¾	0 ... 2.5 bar	0 ... 6 bar	0 ... 1 bar	1000 bar

⁽¹⁾ and corresponding compound pressure ranges

⁽²⁾ lower pressure ranges on request

Dimensions

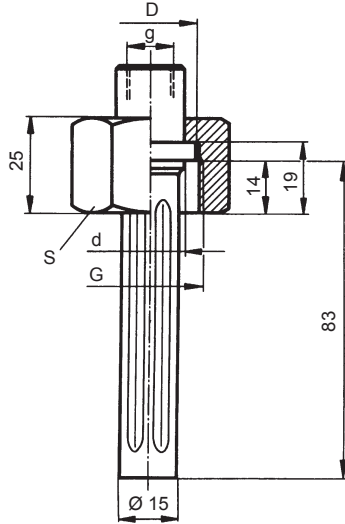

Dimension chart

G	Sealing ring	g	Ø D	Ø d	S	Weight kg
G 1	A25 x 30 DIN 7603	G ½	30	24	41	0.25
G ¾	A18 x 24 DIN 7603	G ¼	25	18	36	0.25

Ordering example

MEX	5	-	D	3	0	.	B22	/	1511	-	9007	-	0080	-	LRS1
-----	---	---	---	---	---	---	-----	---	------	---	------	---	------	---	------

Tongue diaphragm seal, G 1

Option: Adjustment at specific fluid temperature

Adjustment temperature: 80 °C

Filling fluid LRS1: Vaseline (-15 ... +150 °C)