



Main

Range of product	OsiSense XM
Pressure sensor type	Electromechanical pressure sensor
Pressure sensor name	FTG
Pressure sensor size	4.6 bar
Fluid connection type	R 1/4 (male) conforming to ISO 7
Controlled fluid	Sea water (0...70 °C) Fresh water (0...70 °C)
Cable entry	2 cable entries with grommet
Contacts type and composition	2 NC snap action
Product specific application	-
Pressure switch type of operation	Detection of single threshold
[In] rated current	10 A at 250 V AC conforming to EN 60730-1
Electrical connection	Screw-clamp terminals, clamping capacity: 1 x 1...2 x 2 mm ²
Short circuit protection	20 A cartridge fuse type gG
Scale type	Fixed differential
Setting	Internal
Local display	Without
Electrical circuit type	Power circuit

Complementary

Materials in contact with fluid	Nitrile Nylon 6/6 Zinc plated steel
Enclosure material	PS
Operating position	Any position
Motor power kW	1.5 kW/2 hp at 400 V AC, 3 phases 1.5 kW/2 hp at 230 V AC, 3 phases 1.1 kW/1.5 hp at 230 V AC, 1 phase 1.5 kW/2 hp at 400 V AC, 1 phase 1.1 kW/1.5 hp at 110 V AC, 3 phases 0.75 kW/1 hp at 110 V AC, 1 phase
Adjustable range of switching point on falling pressure	0.3...3.1 bar
Adjustable range of switching point on rising pressure	1.4...4.6 bar
Maximum permissible accidental pressure	8 bar
Maximum permissible pressure - per cycle	5.75 bar
Destruction pressure	20 bar
Pressure actuator	Diaphragm
Electrical durability	40000 cycles at 10 cyc/mn
Mechanical durability	400000 cycles
Terminal block type	4 terminals
Natural differential at low setting	1.1 bar
Natural differential at middle setting	1.3 bar
Natural differential at high setting	1.5 bar

Operating rate	10 cyc/mn
[Ui] rated insulation voltage	500 V conforming to EN/IEC 60947-1
[Uimp] rated impulse withstand voltage	6 kV conforming to EN/IEC 60947-1
Product weight	0.34 kg
Repeat accuracy	< 2 %
Terminals description ISO n°1	(1-2)NC (3-4)NC
Depth	102 mm
Height	105 mm
Width	72 mm

Environment

Standards	CE EN/IEC 60730
Ambient air temperature for operation	0...45 °C
Ambient air temperature for storage	-30...80 °C
Protective treatment	TC
Class of protection against electric shock	Class I conforming to IEC 536
IP degree of protection	IP20 conforming to EN/IEC 60529

Offer Sustainability

Sustainable offer status	Green Premium product
RoHS (date code: YYWW)	Compliant - since 0627 - Schneider Electric declaration of conformity
REACH	Reference contains SVHC above the threshold - go to CaP for more details
Product environmental profile	Available Download Product Environmental
Product end of life instructions	Available Download End Of Life Manual

Dimensions

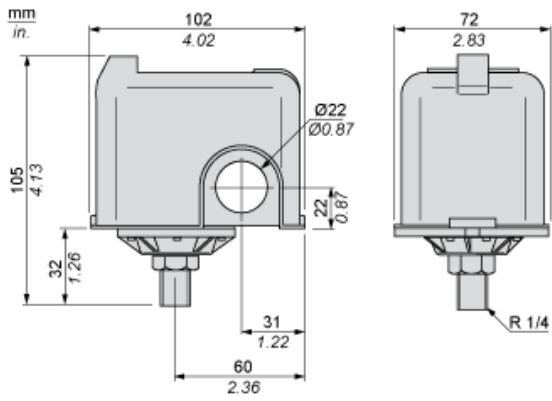

Wiring Diagram

Connections



Curves

Operating Curves

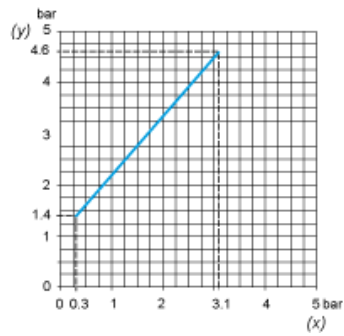

- (y) Rising pressure
- (x) Falling pressure

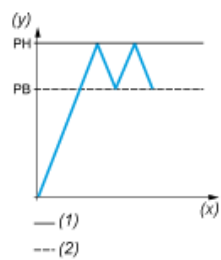

- (y) Pressure
- (x) Time
- (1) Adjustable value
- (2) Non adjustable value