

OG5130

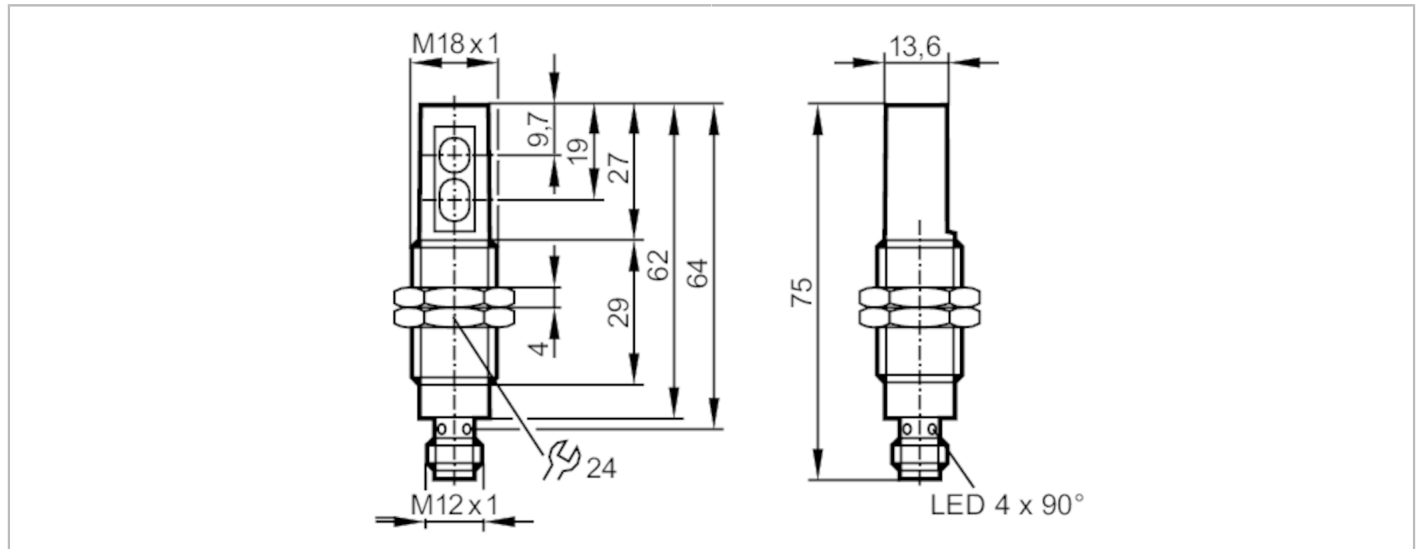

Diffuse reflection sensor with background suppression

OGH-CPKG/US/90°/70MM



Application	
Function principle	Diffuse reflection sensor
Electrical data	
Operating voltage [V]	10...30 DC; ("supply class 2" to cULus)
Current consumption [mA]	25
Protection class	II
Reverse polarity protection	yes
Type of light	red light
Wave length [nm]	625
Outputs	
Electrical design	PNP
Output function	complementary
Max. voltage drop switching output DC [V]	2.5
Permanent current rating of switching output DC [mA]	200
Switching frequency DC [Hz]	1000
Short-circuit protection	yes
Type of short-circuit protection	pulsed
Overload protection	yes
Detection zone	
Range [mm]	< 70; (white paper 200 x 200 mm 90 % remission)
Range adjustable	no
Max. light spot diameter [mm]	16
Light spot dimensions refer to	at maximum range
Background suppression available	yes

OG5130



Diffuse reflection sensor with background suppression

OGH-CPKG/US/90°/70MM

Operating conditions		
Ambient temperature	[°C]	-25...60
Protection		IP 68
Tests / approvals		
EMC		EN 60947-5-2
		EN 55011
		class B
MTTF	[years]	492
Mechanical data		
Weight	[g]	63.4
Housing		threaded type
Dimensions	[mm]	M18 x 1 / L = 65
Thread designation		M18 x 1
Materials		stainless steel; ABS
Lens material		PMMA
Displays / operating elements		
Display	switching status	1 x LED, yellow
	operation	1 x LED, green
Accessories		
Accessories (supplied)		Nuts: 2 x lock washers: 2 x
Remarks		
Pack quantity		1 pcs.
Electrical connection		
Connector: 1 x M12		
		

OG5130



Diffuse reflection sensor with background suppression

OGH-CPKG/US/90°/70MM

Connection

