



Main

Range of product	Modicon STB distributed I/O solution
Product or component type	Standard digital input kit
Kit composition	STBDDI3610 module STBXBA1000 base STBXTS1100, 6-terminal screw type connector STBXTS2100, 6-terminal spring clamp connector
Discrete input number	6
Discrete input voltage	24 V
Discrete input voltage type	DC

Complementary

Input voltage limits	-3...5 V at state 0 15...30 V at state 1
Permissible voltage	30 V
Absolute maximum voltage	56 V 1.3 ms
Discrete input current	4.5 mA
Input current limits	<= 0.5 mA at state 0 >= 2 mA at state 1
Discrete input logic	Positive or negative
Response time	1.74 ms on-to-off 1.21 ms off-to-on
Protection type	Power protection integrated fuse on PDM time lag 10 A Input protection resistor-limited Reverse polarity protection
Insulation between channels and logic bus	1500 V for 1 minute
Cold swapping	Yes
Hot swapping	Yes for standard NIMs
Input filtering	1 ms
Product compatibility	I/O base STBXBA1000 Power distribution module STBPDT3100/3105
[Us] rated supply voltage	24 V DC
Supply	Power distribution module
Current consumption	55 mA 5 V DC logic bus
Marking	CE
Overvoltage category	II
Status LED	1 LED red module error (ERR) 1 LED per channel green channel status (IN1 to IN6) 1 LED green module status (RDY)
Depth	65.1 mm
Height	18.4 mm
Width	125 mm
Product weight	0.112 kg

The information provided in this documentation contains general descriptions and/or technical characteristics of the performance of the products contained herein. This documentation is not intended as a substitute for and is not to be used for determining suitability or reliability of these products for specific user applications. It is the duty of any such user or integrator to perform the appropriate and complete risk analysis, evaluation and testing of the products with respect to the relevant specific application or use thereof. Neither Schneider Electric Industries SAS nor any of its affiliates or subsidiaries shall be responsible or liable for misuse of the information contained herein.

Environment

Standards	EN/IEC 61131-2 type 1
Product certifications	CSA FM Class 1 Division 2 UL
Pollution degree	2 IEC 60664-1
Operating altitude	<= 2000 m
IP degree of protection	IP20 EN 61131-2 class 1
Ambient air temperature for operation	-25...70 °C without derating
Ambient air temperature for operation	32...140 °F without
Ambient air temperature for storage	-40...85 °C without
Ambient air temperature for storage	-40...185 °F without
Relative humidity	95 % 60 °C without condensation
Vibration resistance	5 gn 58...150 Hz 35 x 15 mm symmetrical DIN rail 3 gn 58...150 Hz 35 x 7.5 mm symmetrical DIN rail +/-0.35 mm 10...58 Hz
Shock resistance	30 gn 11 ms IEC 88 reference 2-27

Offer Sustainability

Sustainable offer status	Not Green Premium product
RoHS (date code: YYWW)	Compliant - since 0936 - Schneider Electric declaration of conformity
REACH	Reference not containing SVHC above the threshold
Product environmental profile	Available Download Product Environmental

Dimensions

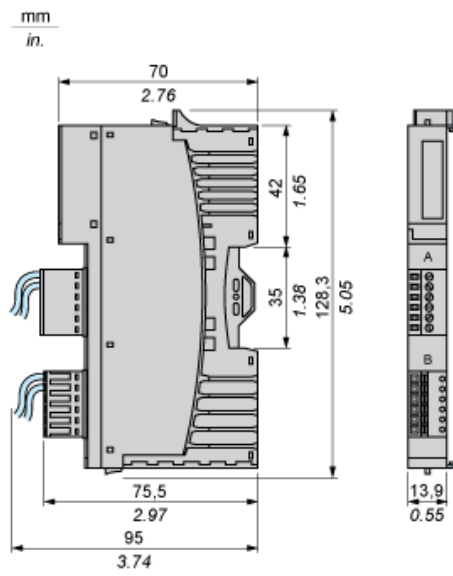

Wiring Diagram

Example

6 two-wire sensors

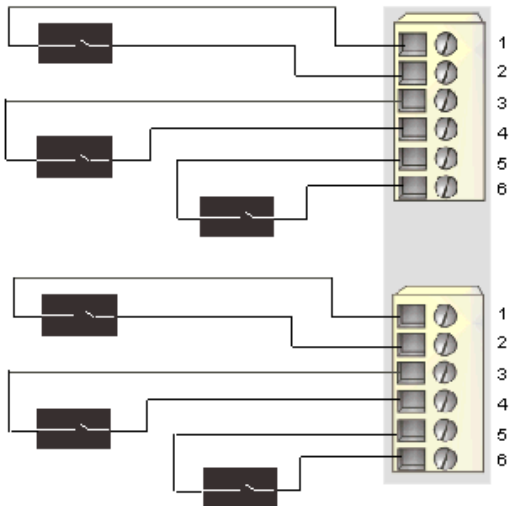

Pin	Top Connector	Bottom Connector
1	+24 VDC sensor bus power	+24 VDC sensor bus power
2	input from sensor 1	input from sensor 4
3	+24 VDC sensor bus power	+24 VDC sensor bus power
4	input from sensor 2	input from sensor 5
5	+24 VDC sensor bus power	+24 VDC sensor bus power
6	input from sensor 3	input from sensor 6