



Main

Range of product	OsiSense XC
Series name	Special format
Product or component type	Limit switch
Product specific application	Materials handling
Device short name	XC1AC
Sensor design	-
Body type	Fixed
Head type	Plunger head
Material	Metal
Fixing mode	By the body
Movement of operating head	Linear
Type of operator	Spring return plunger metal
Switch actuation	On end
Type of approach	Vertical approach, 1 direction
Electrical connection	Screw-clamp terminals, clamping capacity: 1 x 0.5...1 x 2.5 mm ²
Cable entry	3 entries tapped for Pg 13.5 cable gland, cable outer diameter: 9...12 mm
Number of poles	2
Contacts type and composition	2 NO
Contact operation	Slow-break, staggered
Number of steps	1
Positive opening	Without
Minimum force for tripping	33 N

Complementary

Contacts insulation form	Zb
Maximum actuation speed	0.5 m/s
[I _{th}] conventional enclosed thermal current	10 A
[U _i] rated insulation voltage	500 V AC
Maximum resistance across terminals	8 mOhm
Short-circuit protection	10 A cartridge fuse, type gG

Electrical durability	1000000 cycles, AC-15 f = 50/60 Hz, inductive load type, 110 V, 900 VA, operating rate <60 cyc/mn, load factor: 0.5 conforming to IEC 60947-5-1 appendix C 1000000 cycles, AC-15 f = 50/60 Hz, inductive load type, 230 V, 1900 VA, operating rate <60 cyc/mn, load factor: 0.5 conforming to IEC 60947-5-1 appendix C 1000000 cycles, AC-15 f = 50/60 Hz, inductive load type, 48 V, 450 VA, operating rate <60 cyc/mn, load factor: 0.5 conforming to IEC 60947-5-1 appendix C 1000000 cycles, DC-13, inductive load type, 110 V, 100 W, operating rate <60 cyc/mn, load factor: 0.5 conforming to IEC 60947-5-1 appendix C 1000000 cycles, DC-13, inductive load type, 230 V, 95 W, operating rate <60 cyc/mn, load factor: 0.5 conforming to IEC 60947-5-1 appendix C 1000000 cycles, DC-13, inductive load type, 48 V, 100 W, operating rate <60 cyc/mn, load factor: 0.5 conforming to IEC 60947-5-1 appendix C 3000000 cycles, AC-15 f = 50/60 Hz, inductive load type, 110 V, 350 VA, operating rate <60 cyc/mn, load factor: 0.5 conforming to IEC 60947-5-1 appendix C 3000000 cycles, AC-15 f = 50/60 Hz, inductive load type, 230 V, 430 VA, operating rate <60 cyc/mn, load factor: 0.5 conforming to IEC 60947-5-1 appendix C 3000000 cycles, AC-15 f = 50/60 Hz, inductive load type, 48 V, 170 VA, operating rate <60 cyc/mn, load factor: 0.5 conforming to IEC 60947-5-1 appendix C 3000000 cycles, DC-13, inductive load type, 110 V, 40 W, operating rate <60 cyc/mn, load factor: 0.5 conforming to IEC 60947-5-1 appendix C 3000000 cycles, DC-13, inductive load type, 230 V, 33 W, operating rate <60 cyc/mn, load factor: 0.5 conforming to IEC 60947-5-1 appendix C 3000000 cycles, DC-13, inductive load type, 48 V, 35 W, operating rate <60 cyc/mn, load factor: 0.5 conforming to IEC 60947-5-1 appendix C
Mechanical durability	10000000 cycles
Width	77 mm
Height	113 mm
Depth	44 mm
Product weight	0.53 kg
Terminals description ISO n°1	(13-14)NO (11-12)NC

Environment

Shock resistance	95 gn for 11 ms conforming to IEC 60068-2-27
Vibration resistance	9 gn (f= 10...500 Hz) conforming to IEC 60068-2-6
IP degree of protection	IP65 conforming to IEC 60529 IP65 conforming to NF C 20-010
Electrical shock protection class	Class I conforming to IEC 61140 Class I conforming to NF C 20-030
Ambient air temperature for operation	-25...70 °C
Ambient air temperature for storage	-40...70 °C
Protective treatment	TC
Operating position	Any position
Product certifications	CSA
Standards	IEC 947-5-1 IEC 337-1 CSA C22.2 No 14 VDE 0660-200 EN 60947-5-1

Offer Sustainability

EU RoHS Directive	Not applicable, out of EU RoHS legal scope
Environmental Disclosure	Product Environmental Profile
Circularity Profile	No need of specific recycling operations

Contractual warranty

Warranty	18 months
----------	-----------

Dimensions

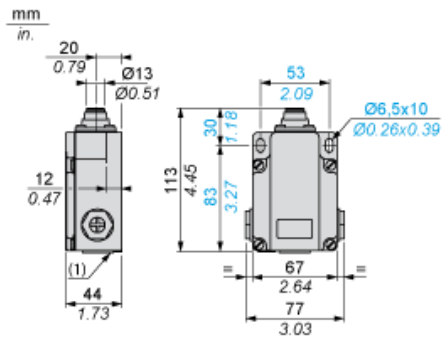

(1) 3 tapped entries for Pg 13.5 cable gland

Adaptator Dimensions for ISO M20 x 1.5



Wiring Diagram

2-pole NO + NO Staggered, Slow Break

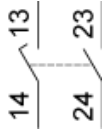

Characteristics of Actuation

Switch Actuation on End

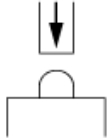

Functionnal Diagram

