

XCKML121H29

limit switch XCKML - th.plastic roller lever
plunger - 2x(1NO+1NC) - snap - M20

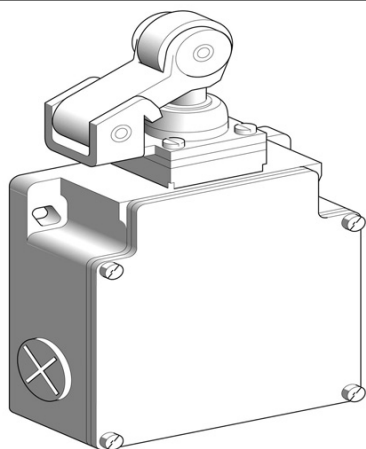

Main

Range of product	OsiSense XC
Series name	Standard format
Product or component type	Limit switch
Device short name	XCKML
Sensor design	-
Body type	Fixed
Head type	Plunger head
Material	Metal
Fixing mode	By the body
Movement of operating head	Linear
Type of operator	Thermoplastic spring return roller lever plunger
Type of approach	1 direction lateral approach
Electrical connection	Screw-clamp terminals , clamping capacity: 1 x 0.34...2 x 1.5 mm ²
Cable entry	3 entries tapped for M20 x 1.5 cable gland , cable outer diameter: 7...13 mm
Number of poles	4
Contacts type and composition	2 x (1 NC + 1 NO)
Contacts operation	Snap action
Positive opening	With

Complementary

Body material	Zamak
Switch actuation	By 30° cam
Contacts insulation form	Zb
Number of steps	1
Positive opening minimum force	50 N
Minimum force for tripping	8 N
Minimum actuation speed	0.01 m/min
Maximum actuation speed	1.5 m/s
[Ithe] conventional enclosed thermal current	10 A AC
[Ui] rated insulation voltage	300 V conforming to UL 508 300 V conforming to CSA C22-2 No 14 500 V degree of pollution 3 conforming to IEC 60947-1
Resistance across terminals	≤ 25 mOhm conforming to IEC 60255-7 category 3
[Uimp] rated impulse withstand voltage	6 kV conforming to IEC 60947-1 6 kV conforming to IEC 60664
Electrical durability	5000000 cycles , DC-13 inductive load type, 120 V , 4 W , load factor: 0.5 , operating rate: ≤ 60 cyc/mn 5000000 cycles , DC-13 inductive load type, 48 V , 7 W , load factor: 0.5 , operating rate: ≤ 60 cyc/mn 5000000 cycles , DC-13 inductive load type, 24 V , 10 W , load factor: 0.5 , operating rate: ≤ 60 cyc/mn
Mechanical durability	3000000 cycles
Width	81 mm
Height	77 mm
Depth	35.6 mm
Product weight	0.45 kg

Environment

Shock resistance	50 gn (duration = 11 ms) conforming to IEC 60068-2-27
Vibration resistance	25 gn (f = 10...500 Hz) conforming to IEC 60068-2-6
IP degree of protection	IP66 conforming to IEC 60529
IK degree of protection	IK05 conforming to EN 50102
Class of protection against electric shock	Class I conforming to IEC 61140 Class I conforming to NF C 20-030
Ambient air temperature for operation	-25...70 °C
Ambient air temperature for storage	-40...70 °C
Protective treatment	TC
Product certifications	CSA UL
Standards	CSA C22-2 No 14 EN 60204-1 EN 60947-5-1 IEC 60204-1 IEC 60947-5-1 UL 508
RoHS EUR conformity date	4Q2009
RoHS EUR status	Will be compliant