

XMLBM03S2S13

vacuum sensor XMLB 0.2 bar - adjustable
scale 2 threshold - 1 C/O - with display



Main

Range of product	OsiSense XM
Product or component type	Electromechanical pressure sensor
Pressure sensor type	Electromechanical vacuum sensor
Device short name	XMLB
Pressure sensor size	0.2 bar
Controlled fluid	Fresh water (0...160 °C) Corrosive fluid (0...160 °C)
Fluid connection type	1/4" - 18 NPTF (female)
Electrical connection	Screw-clamps terminals 1 x 0.5...2 x 2.5 mm ²
AWG gauge	AWG 20...AWG 14
Cable entry number	1 tapped entry (1/2" NPT) forcable gland , cable outer diameter: 7...13 mm
Contacts type and composition	1 C/O
Product specific application	-
Pressure switch type of operation	Regulation between 2 thresholds
Electrical circuit type	Control circuit
Scale type	Adjustable differential
Local display	With
Adjustable range of switching point on rising pressure	-0.182...-0.002 bar
Adjustable range of switching point on falling pressure	-0.2...-0.02 bar
Possible differential maximum at high setting	0.18 bar
Maximum permissible accidental pressure	2 bar
Destruction pressure	3.5 bar
Pressure actuator	Diaphragm
Materials in contact with fluid	Aluminium PTFE 316L stainless steel
Enclosure material	Zinc alloy
[In] rated current	0.1 A, R300, DC-13 (Ue = 250 V) conforming to EN/IEC 60947-5-1 1.5 A, B300, AC-15 (Ue = 240 V) conforming to EN/IEC 60947-5-1 3 A, B300, AC-15 (Ue = 120 V) conforming to EN/IEC 60947-5-1

Complementary

Possible differential minimum at low setting	0.018 bar (+/- 2 mbar)
Possible differential minimum at high setting	0.018 bar (+/- 2 mbar)
Maximum permissible pressure - per cycle	1 bar
Terminal block type	4 terminals
Operating rate	<= 120 cyc/mn at > 0 °C

Repeat accuracy	< 2 %
[Ui] rated insulation voltage	300 V conforming to CSA C22.2 No 14 500 V conforming to EN/IEC 60947-1 300 V conforming to UL 508
[Uimp] rated impulse withstand voltage	6 kV conforming to EN/IEC 60947-1
Auxiliary contacts operation	Snap action
Contacts material	Silver contacts
Resistance across terminals	< 25 mOhm conforming to NF C 93-050 method A < 25 mOhm conforming to IEC 255-7 category 3
Short circuit protection	10 A cartridge fuse type gG (gl)
Mechanical durability	3000000 cycles
Setting	External
Height	145 mm
Depth	156 mm
Width	150 mm
Product weight	3.31 kg

Environment

Standards	CE EN/IEC 60947-5-1 UL 508 CSA C22.2 No 14
Product certifications	BV CCC CSA LROS (Lloyds register of shipping) UL EAC
Protective treatment	TC (standard version)
Ambient air temperature for operation	-25...70 °C
Ambient air temperature for storage	-40...70 °C
Operating position	Any position
Vibration resistance	2 gn (f = 30...500 Hz) conforming to IEC 60068-2-6
Shock resistance	30 gn conforming to IEC 60068-2-27
Class of protection against electric shock	Class I conforming to NF C 20-030 Class I conforming to IEC 536 Class I conforming to IEC 1140
IP degree of protection	IP66 conforming to EN/IEC 60529

Offer Sustainability

Sustainable offer status	Green Premium product
RoHS (date code: YYWW)	Compliant - since 0928 - Schneider Electric declaration of conformity
REACH	Reference not containing SVHC above the threshold
Product environmental profile	Available Download Product Environmental
Product end of life instructions	Need no specific recycling operations

Dimensions

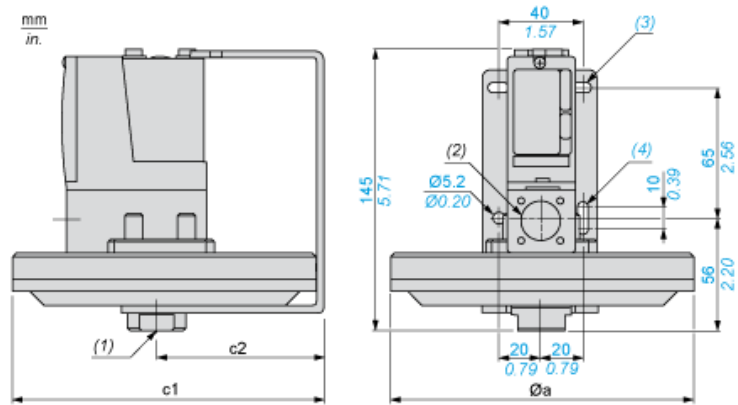

$\varnothing a = 150$
 $c1 = 155.5$
 $c2 = 80.5$

- (1) 1 fluid entry, tapped 1/4" NPTF
- (2) 1 electrical connections entry, tapped 1/2" NPT
- (3) 2 elongated holes $\varnothing 10.2 \times 5.2$
- (4) 1 elongated hole $\varnothing 15.2 \times 5.2$

Wiring Diagram

Terminal Model



Operating Curves

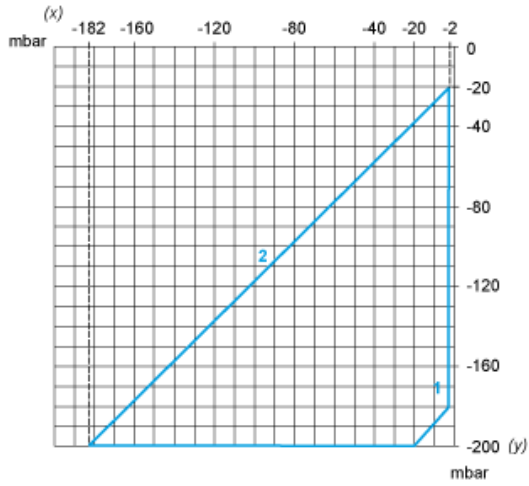

- (x) Rising pressure
- (y) Falling pressure
- 1 : Maximum differential
- 2 : Minimum differential

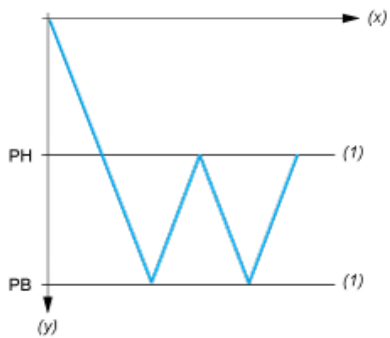

- (x) Time
- (y) Vacuum
- (1) Adjustable value
- PH : High point
- PB : Below point