



### Main

Range of product	OsiSense XM
Product or component type	Electromechanical pressure sensor
Pressure sensor type	Electromechanical pressure sensor
Device short name	XMLC
Pressure sensor size	1 bar
Controlled fluid	Corrosive fluid (0...160 °C) Fresh water (0...160 °C)
Fluid connection type	1/4" - 18 NPTF (female)
Electrical connection	Screw-clamps terminals, 1 x 0.5...2 x 2.5 mm <sup>2</sup>
AWG gauge	AWG 20...AWG 14
Cable entry	Cable gland 7...13 mm
Contacts type and composition	2 C/O
Product specific application	-
Pressure switch type of operation	Regulation between 2 thresholds
Electrical circuit type	Control circuit
Scale type	Adjustable differential
Local display	With
Adjustable range of switching point on rising pressure	0.05...1 bar
Adjustable range of switching point on falling pressure	0.02...0.96 bar
Possible differential maximum at high setting	0.8 bar
Maximum permissible accidental pressure	2.25 bar
Destruction pressure	4.5 bar
Pressure actuator	Diaphragm
Materials in contact with fluid	PTFE 316L stainless steel

Disclaimer: This documentation is not intended as a substitute for and is not to be used for determining suitability or reliability of these products for specific user applications

Enclosure material	Zinc alloy
[In] rated current	3 A, B300, AC-15 (Ue = 120 V) conforming to EN/IEC 60947-5-1 1.5 A, B300, AC-15 (Ue = 240 V) conforming to EN/IEC 60947-5-1 0.1 A, R300, DC-13 (Ue = 250 V) conforming to EN/IEC 60947-5-1

## Complementary

Possible differential minimum at low setting	0.03 bar (+/- 0.01 bar)
Possible differential minimum at high setting	0.04 bar (+/- 0.03 bar)
Maximum permissible pressure - per cycle	1.25 bar
Terminal block type	8 terminals
Maximum operating rate	120 cyc/mn
Repeat accuracy	2 %
[Ui] rated insulation voltage	300 V conforming to UL 508 500 V conforming to EN/IEC 60947-1 300 V conforming to CSA C22.2 No 14
[Uimp] rated impulse withstand voltage	6 kV EN/IEC 60947-1
Auxiliary contacts operation	Simultaneous, snap action
Contacts material	Silver contacts
Maximum resistance across terminals	25 mOhm conforming to IEC 255-7 category 3 25 mOhm conforming to NF C 93-050 method A
Short-circuit protection	10 A cartridge fuse, type gG (gl)
Mechanical durability	4000000 cycles
Setting	External
Height	162 mm
Depth	110 mm
Width	110 mm
Product weight	2.555 kg

## Environment

Standards	CE UL 508 CSA C22.2 No 14 EN/IEC 60947-5-1
Product certifications	UL EAC CSA
Protective treatment	TC standard version
Ambient air temperature for operation	-25...70 °C
Ambient air temperature for storage	-40...70 °C
Operating position	Any position
Vibration resistance	2 gn conforming to IEC 60068-2-6 (f = 30...500 Hz)
Shock resistance	30 gn conforming to IEC 60068-2-27
Electrical shock protection class	Class I conforming to IEC 1140 Class I conforming to IEC 536 Class I conforming to NF C 20-030
IP degree of protection	IP66 conforming to EN/IEC 60529

## Offer Sustainability

Sustainable offer status	Green Premium product
EU RoHS Directive	Pro-active compliance (Product out of EU RoHS legal scope) <a href="#">EU RoHS Declaration</a>
Mercury free	Yes
RoHS exemption information	<a href="#">Yes</a>
Environmental Disclosure	<a href="#">Product Environmental Profile</a>

---

Circularity Profile	No need of specific recycling operations
---------------------	--

---

### Contractual warranty

---

Warranty	18 months
----------	-----------

---

Dimensions

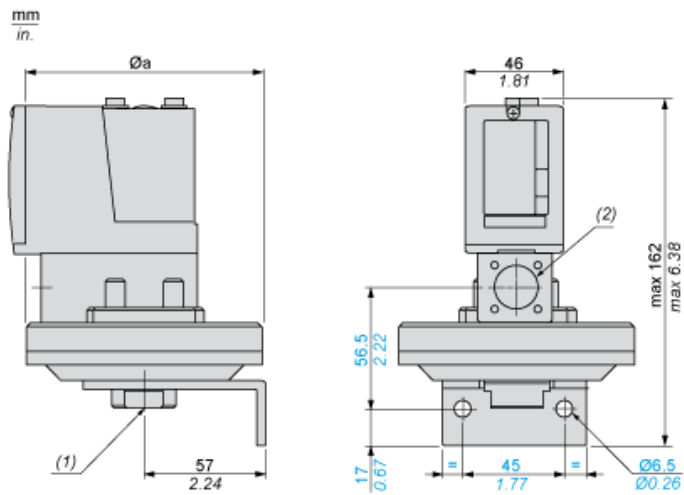

$\varnothing a =$  110 mm / 4.33 in.

(1) 1 fluid entry, tapped 1/4" NPTF

(2) 1 electrical connections entry, tapped 1/2" NPT

---

Wiring Diagram

---

Terminal Model

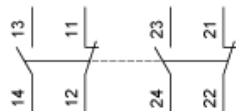

Operating Curves

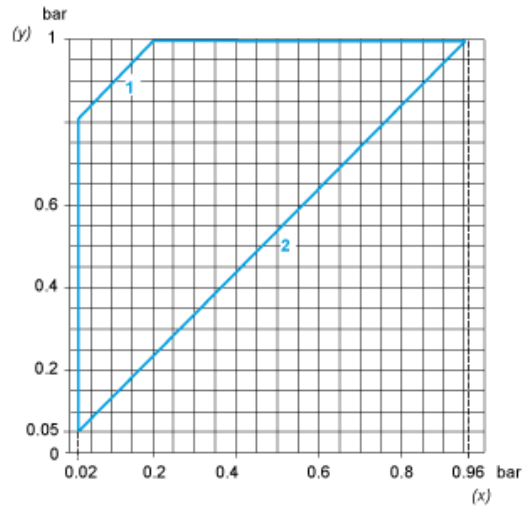

- (y) Rising pressure
- (x) Falling pressure
- 1 : Maximum differential
- 2 : Minimum differential

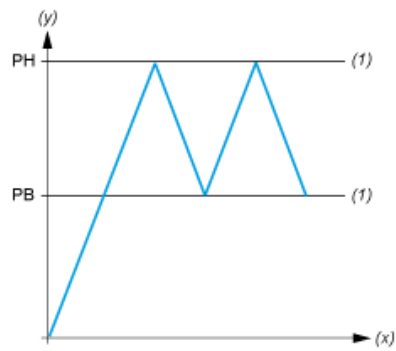

- (y) Pressure
- (x) Time
- (1) Adjustable value
- PH : High point
- PB : Below point