

XMLCS35R2S11

pressure switch XMLC 330 mbar - adjustable
scale 2 thresholds - 1 C/O



Main

Range of product	OsiSense XM
Product or component type	Electromechanical pressure sensor
Pressure sensor type	Electromechanical pressure sensor
Device short name	XMLC
Pressure sensor size	0.35 bar
Controlled fluid	Hydraulic oil (0...160 °C) Air (0...160 °C)
Fluid connection type	G 1/4 (female) conforming to ISO 228
Electrical connection	Screw-clamps terminals 1 x 0.5...2 x 2.5 mm ²
AWG gauge	AWG 20...AWG 14
Cable entry number	1 tapped entry (Pg 13.5) forcable gland , cable outer diameter: 9...13 mm
Contacts type and composition	2 C/O
Product specific application	30 bar overpressure
Pressure switch type of operation	Regulation between 2 thresholds
Electrical circuit type	Control circuit
Scale type	Adjustable differential
Local display	With
Adjustable range of switching point on rising pressure	0.042...0.33 bar
Adjustable range of switching point on falling pressure	0.002...0.242 bar
Possible differential maximum at high setting	0.23 bar
Maximum permissible accidental pressure	37.5 bar
Destruction pressure	67.5 bar
Pressure actuator	Diaphragm
Materials in contact with fluid	FPM, FKM Steel 304L stainless steel
Enclosure material	Zinc alloy
[In] rated current	0.1 A, R300, DC-13 (Ue = 250 V) conforming to EN/ IEC 60947-5-1 1.5 A, B300, AC-15 (Ue = 240 V) conforming to EN/ IEC 60947-5-1 3 A, B300, AC-15 (Ue = 120 V) conforming to EN/ IEC 60947-5-1

Complementary

Possible differential minimum at low setting	0.04 bar (+/- 20 mbar)
Possible differential minimum at high setting	0.088 bar (+/- 20 mbar)
Maximum permissible pressure - per cycle	30 bar
Terminal block type	8 terminals
Operating rate	<= 120 cyc/mn at > 0 °C

Repeat accuracy	< 2 %
[Ui] rated insulation voltage	300 V conforming to CSA C22.2 No 14 500 V conforming to EN/IEC 60947-1 300 V conforming to UL 508
[Uimp] rated impulse withstand voltage	6 kV conforming to EN/IEC 60947-1
Auxiliary contacts operation	Simultaneous, snap action
Contacts material	Silver contacts
Resistance across terminals	< 25 mOhm conforming to NF C 93-050 method A < 25 mOhm conforming to IEC 255-7 category 3
Short circuit protection	10 A cartridge fuse type gG (gl)
Mechanical durability	2000000 cycles
Setting	External
Height	113 mm
Depth	85 mm
Width	46 mm
Product weight	3.5 kg

Environment

Standards	CE EN/IEC 60947-5-1 UL 508 CSA C22.2 No 14
Product certifications	CSA UL EAC
Protective treatment	TC (standard version)
Ambient air temperature for operation	-25...70 °C
Ambient air temperature for storage	-40...70 °C
Operating position	Any position
Vibration resistance	4 gn (f = 30...500 Hz) conforming to IEC 60068-2-6
Shock resistance	50 gn conforming to IEC 60068-2-27
Class of protection against electric shock	Class I conforming to NF C 20-030 Class I conforming to IEC 536 Class I conforming to IEC 1140
IP degree of protection	IP66 conforming to EN/IEC 60529

Offer Sustainability

Sustainable offer status	Green Premium product
RoHS (date code: YYWW)	Compliant - since 0928 - Schneider Electric declaration of conformity
REACH	Reference not containing SVHC above the threshold
Product environmental profile	Available Download Product Environmental
Product end of life instructions	Need no specific recycling operations

Dimensions

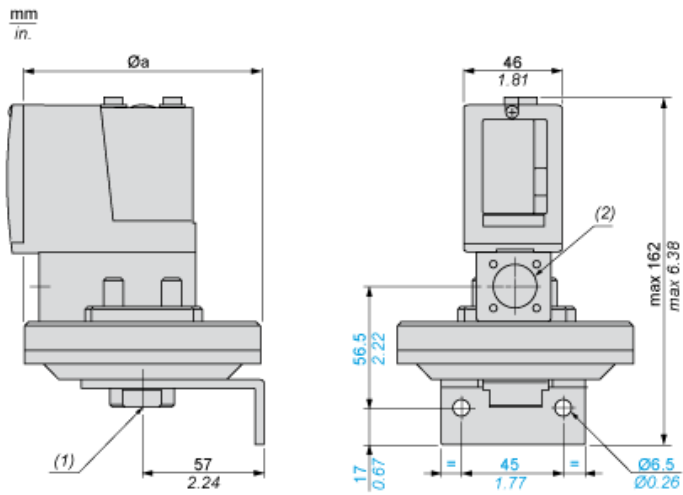

$\varnothing a = 110 \text{ mm} / 4.33 \text{ in.}$

- (1) 1 fluid entry, tapped G1/4 (BSP female)
- (2) 1 electrical connections entry, tapped Pg 13.5

Wiring Diagram

Terminal Model



Operating Curves

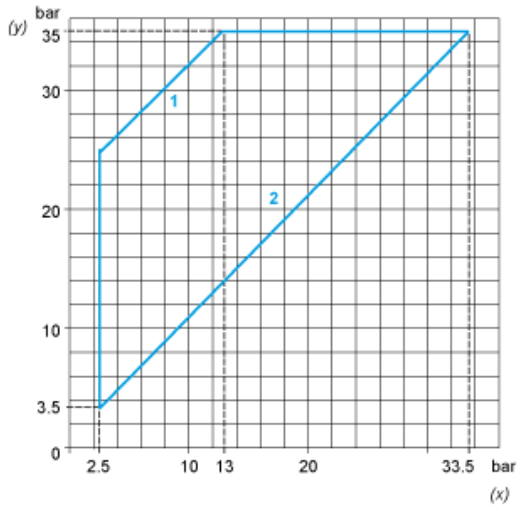

- (y) Rising pressure
- (x) Falling pressure
- 1 : Maximum differential
- 2 : Minimum differential



- (y) Pressure
- (x) Time
- (1) Adjustable value
- PH : High point
- PB : Below point