



Main

| | |
|---|--|
| Range of product | OsiSense XM |
| Product or component type | Electromechanical pressure sensor |
| Pressure sensor type | Electromechanical vacuum sensor |
| Device short name | XMLD |
| Pressure sensor size | -1 bar |
| Controlled fluid | Hydraulic oil (0...70 °C) Fresh water (0...70 °C) Air (0...70 °C) |
| Fluid connection type | G 1/4 (female) conforming to ISO 228 |
| Electrical connection | Screw-clamps terminals 1 x 0.5...2 x 2.5 mm ² |
| AWG gauge | AWG 20...AWG 14 |
| Cable entry number | 1 tapped entry (Pg 13.5) forcable gland , cable outer diameter: 9...13 mm |
| Contacts type and composition | 2 C/O staggered, silver contacts 2 C/O snap action, silver contacts |
| Product specific application | Dual stage |
| Pressure switch type of operation | Detection of 2 single thresholds |
| Electrical circuit type | Control circuit |
| Scale type | Fixed differential |
| Local display | Without |
| Maximum permissible accidental pressure | 9 bar |
| Destruction pressure | 18 bar |
| Pressure actuator | Diaphragm |
| Materials in contact with fluid | Nitrile Zinc alloy 304L stainless steel |
| Enclosure material | Zinc alloy |
| [In] rated current | 0.1 A, R300, DC-13 (Ue = 250 V) conforming to EN/IEC 60947-5-1 1.5 A, B300, AC-15 (Ue = 240 V) conforming to EN/IEC 60947-5-1 3 A, B300, AC-15 (Ue = 120 V) conforming to EN/IEC 60947-5-1 |

Complementary

| | |
|--|---|
| Spread between 2 stages | 0.02...0.88 bar |
| Natural differential at low setting | 0.1 bar |
| Natural differential at high setting | 0.1 bar |
| Maximum permissible pressure - per cycle | 5 bar |
| Terminal block type | 8 terminals |
| Operating rate | 0...120 cyc/mn at > 0...70 °C |
| Repeat accuracy | < 2 % |
| [Ui] rated insulation voltage | 300 V conforming to CSA C22.2 No 14 500 V conforming to EN/IEC 60947-1 300 V conforming to UL 508 |
| [Uimp] rated impulse withstand voltage | 6 kV conforming to EN/IEC 60947-1 |

| | |
|-----------------------------|--|
| Resistance across terminals | < 25 mOhm conforming to NF C 93-050 method A < 25 mOhm conforming to IEC 255-7 category 3 |
| Short circuit protection | 10 A cartridge fuse type gG (gl) |
| Mechanical durability | 3000000 cycles |
| Setting | External |
| Height | 158 mm |
| Depth | 90 mm |
| Width | 55 mm |
| Product weight | 1.015 kg |

Environment

| | |
|--|--|
| Standards | CE EN/IEC 60947-5-1 UL 508 CSA C22.2 No 14 |
| Product certifications | CSA UL EAC |
| Protective treatment | TC (standard version) |
| Ambient air temperature for operation | -25...70 °C |
| Ambient air temperature for storage | -40...70 °C |
| Operating position | Any position |
| Vibration resistance | 4 gn (f = 30...500 Hz) conforming to IEC 60068-2-6 |
| Shock resistance | 50 gn conforming to IEC 60068-2-27 |
| Class of protection against electric shock | Class I conforming to NF C 20-030 Class I conforming to IEC 536 Class I conforming to IEC 1140 |
| IP degree of protection | IP66 conforming to EN/IEC 60529 |

Offer Sustainability

| | |
|----------------------------------|---|
| Sustainable offer status | Green Premium product |
| RoHS (date code: YYWW) | Compliant - since 0928 - Schneider Electric declaration of conformity |
| REACH | Reference not containing SVHC above the threshold |
| Product environmental profile | Available Download Product Environmental |
| Product end of life instructions | Need no specific recycling operations |

Dimensions

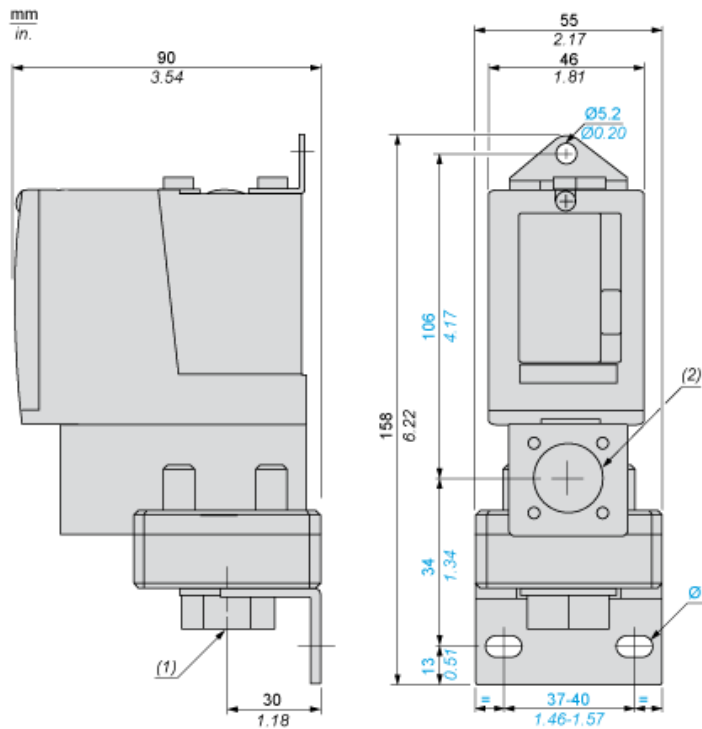

- (1) 1 fluid entry, tapped G1/4 (BSP female)
- (2) 1 electrical connections entry, tapped Pg 13.5
- Ø : 2 elongated holes Ø 10.2 x 5.2

Wiring Diagram

Terminal Model

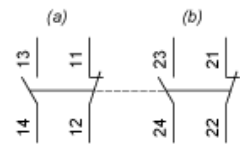

- (a) Contact 1
- (b) Contact 2

Operating Curves

High Setting Tripping Points of Contacts 1 and 2

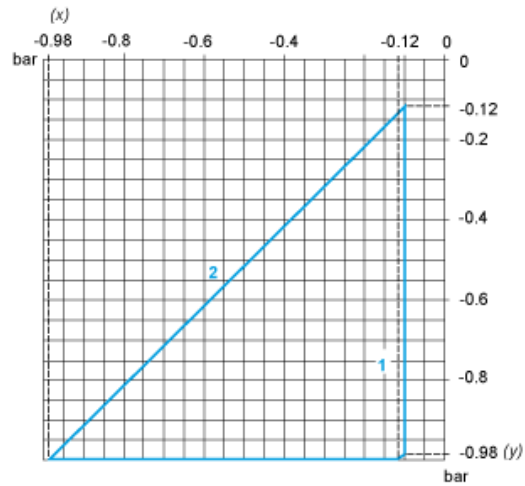

- (x) PH1 setting (falling pressure)
- (y) PH2 setting (falling pressure)
- 1 : Maximum differential
- 2 : Minimum differential

Natural Differential of Contacts 1 and 2

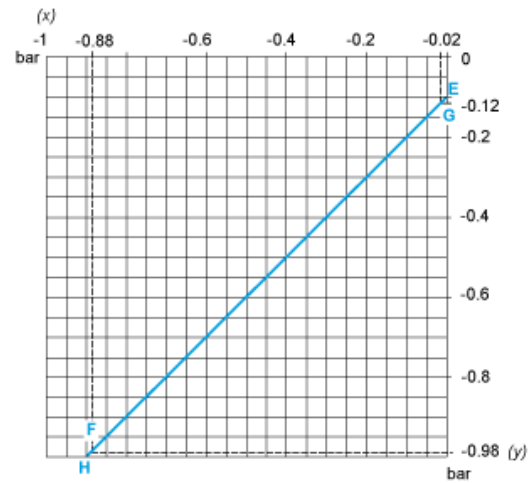

- (x) Rising pressure
- (y) Falling pressure
- EF : Contact 1
- GH : Contact 2

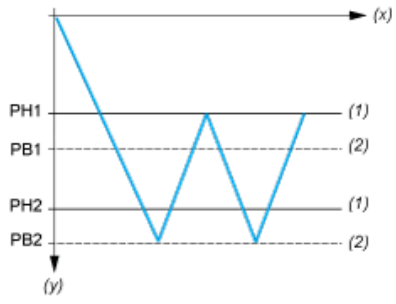

- (x) Time
- (y) Vacuum
- (1) Adjustable value
- (2) Non adjustable value
- PH : High point
- PB : Below point