

Price\* : 164.21 GBP

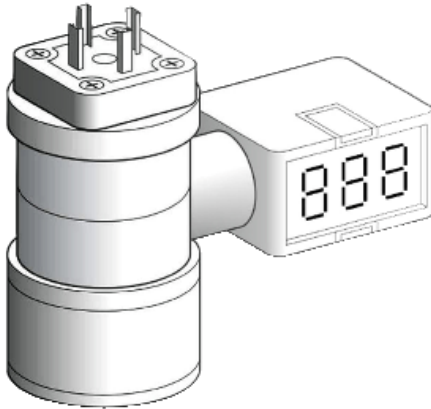

## Main

Accessory / separate part type	Display
Display type	Digital display
Operating position	Any position
Product compatibility	XMLE analogue pressure sensors -1...0 bar, connector type: EN 175301-803-A (ex DIN43650)

## Complementary

Product weight	0.1 kg
Height	66 mm
Depth	40 mm
Width	92 mm

## Environment

Protective treatment	TC
IP degree of protection	IP65 conforming to EN/IEC 60529
Vibration resistance	35 gn (f = 60...2000 Hz) 5 gn (f = 25...200 Hz)
Ambient air temperature for operation	-15...80 °C
Standards	EN 50082 CE EN 50081
Product certifications	CSA UL

## Offer Sustainability

REACH free of SVHC	Yes
EU RoHS Directive	Pro-active compliance (Product out of EU RoHS legal scope) <a href="#">EU RoHS Declaration</a>
Mercury free	Yes
RoHS exemption information	<a href="#">Yes</a>

Contractual warranty

---

Warranty	18 months
----------	-----------

---

Dimensions

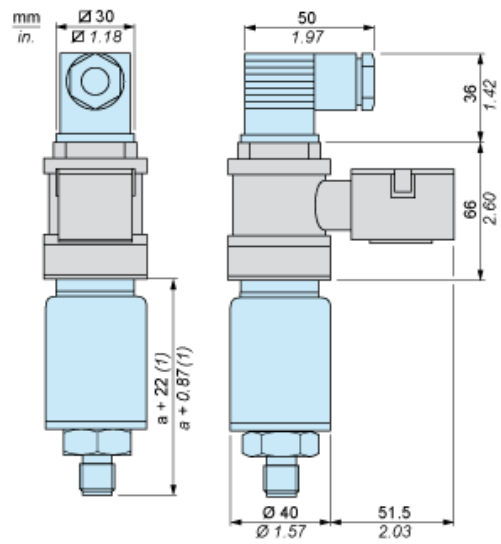

(1) a = 65