

# XMLG250D21TQ

pressure sensor XMLG - 0..250 bars - G 1/4A  
(male) - 24 V - 4..20 mA - set of 25



## Main

Range of product	OsiSense XM
Product or component type	Electronic pressure sensors
Pressure sensor type	Pressure transmitter
Pressure sensor name	XMLG
Pressure sensor size	250 bar
Fluid connection type	G 1/4A (male) conforming to DIN 3852-E
Controlled fluid	Air (-15...125 °C) Corrosive fluid (-15...125 °C) Hydraulic oil (-15...125 °C) Fresh water (0...125 °C)
Type of output signal	Analogue
Analogue output function	4...20 mA, 2 wires
Electrical connection	1 male connector M12, 3 pins
[Us] rated supply voltage	12 V DC (voltage limits: 8...33 V) 24 V DC (voltage limits: 8...33 V)
Quantity per set	Set of 25
Type of packing	Group
Diameter	22.8 mm

## Complementary

Pressure setting range	0...250 bar
Maximum permissible accidental pressure	560 bar
Destruction pressure	625 bar
Local display	Without
Electrical circuit type	Control circuit
Current consumption	< 20 mA
Materials in contact with fluid	Ceramic Stainless steel type AISI 303 FPM (Viton) PPS
Operating position	Any position
Protection type	Load short-circuit Reverse polarity

Disclaimer: This documentation is not intended as a substitute for and is not to be used for determining suitability or reliability of these products for specific user applications

Surge withstand	1 kV 42 Ohm conforming to EN/IEC 61000-4-5 500 kV 12 Ohm conforming to EN/IEC 61000-4-5
[Uimp] rated impulse withstand voltage	0.5 kV
Response time on output	< 2 ms
Drift of the sensitivity	+/- 0.015 % of measuring range/°C
Drift of the zero point	+/- 0.015 % of measuring range/°C
Measurement accuracy	+/- 0.3 % of the measuring range
Repeat accuracy	+/- 0.1 % of the measuring range
Mechanical durability	10000000 cycles
Product weight	0.095 kg
Height	58.1 mm
Length	48.5 mm

## Environment

Standards	CE EN/IEC 61326-2-3
Product certifications	UL 508 EAC CSA C22.2 No 14
Protective treatment	TC
Ambient air temperature for operation	-15...85 °C
Ambient air temperature for storage	-40...85 °C
Vibration resistance	20 gn (f= 9...2000 Hz) conforming to EN/IEC 60028-2-6
Shock resistance	25 gn for 11 ms conforming to EN/IEC 60068-2-27
Resistance to electrostatic discharge	15 kV in air conforming to EN/IEC 61000-4-2 8 kV on contact conforming to EN/IEC 61000-4-2
Resistance to electromagnetic fields	200 V/m 80...1000 Hz conforming to EN/IEC 61000-4-3
Resistance to fast transients	4 kV conforming to EN/IEC 61000-4-4
Resistance to conducted disturbances	30 V (0.15...80 Hz) conforming to EN/IEC 61000-4-6
Resistance to magnetic fields	30 A/m 50 Hz conforming to EN/IEC 61000-4-8
IP degree of protection	IP66 conforming to EN/IEC 60529 IP67 conforming to EN/IEC 60529
NEMA degree of protection	NEMA 4

## Offer Sustainability

REACH free of SVHC	Yes
EU RoHS Directive	Pro-active compliance (Product out of EU RoHS legal scope) <a href="#">EU RoHS Declaration</a>
Mercury free	Yes
RoHS exemption information	<a href="#">Yes</a>

## Contractual warranty

Warranty	18 months
----------	-----------

Dimensions

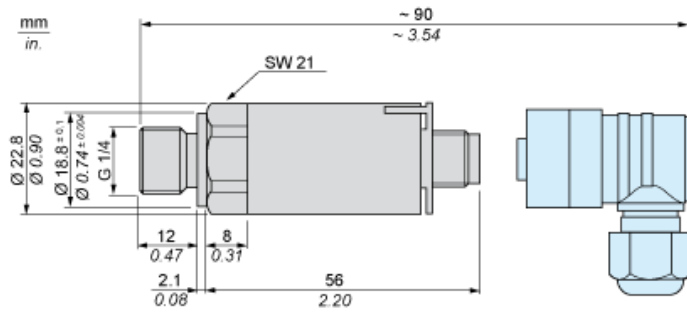

---

Wiring Diagram

---

2-Wire Technique (4-20 mA)

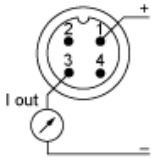

---

## Output Curves

---

