



Price\* : 92.14 GBP



## Main

Range of product	OsiSense XM
Product or component type	Electronic pressure sensors
Pressure sensor type	Pressure transmitter
Pressure sensor name	XMLP
Electrical circuit type	Control circuit
Pressure sensor size	1 bar
Local display	Without
Controlled fluid	Fresh water (0...125 °C) Air (-15...125 °C) Gas (-15...125 °C) Hydraulic oil (-15...125 °C)
Fluid connection type	G 1/4A (male) conforming to DIN 3852-E
Electrical connection	Cable 2 m
[Us] rated supply voltage	24 V DC SELV (voltage limits: 12...33 V)
Current consumption	< 7 mA
Type of output signal	Analogue
Analogue output function	0...10 V, 3-wire
Quantity per set	Set of 1
Type of packing	Individual

## Complementary

Pressure setting range	0...1 bar
Maximum permissible accidental pressure	3 bar
Destruction pressure	5 bar
Materials in contact with fluid	Stainless steel AISI 316L Fluorocarbon FPM Ceramic

Operating position	Any position
Protection type	Reverse polarity Load short-circuit
Electromagnetic compatibility	Susceptibility to electromagnetic fields conforming to EN/IEC 61000-4-3 10 V/m 80...1000 MHz Electrical fast transient/burst immunity test conforming to EN/IEC 61000-4-4 2 kV Radiated RF fields conforming to EN/IEC 61000-4-6 10 V 0.15...80 MHz Electrostatic discharge immunity test conforming to EN/IEC 61000-4-2 8 kV air, 4 kV contact 1.2/50 µs shock waves immunity test conforming to EN/IEC 61000-4-5 1 kV 42 Ohm Immunity to magnetic fields conforming to EN/IEC 61000-4-8 100 A/m 50 Hz
[Uimp] rated impulse withstand voltage	0.5 kV
Response time on output	<= 2 ms 10...90 % of full scale
Measurement accuracy	+/- 0.5 % of the measuring range
Resolution	0.1 % of the measuring range
Drift of the sensitivity	+/- 0.02 % of measuring range/°K
Drift of the zero point	+/- 0.02 % of measuring range/°K
Long term stability	+/- 0.25 % of the measuring range
Mechanical durability	10000000 cycles
Product weight	0.171 kg
Diameter	26 mm
Length	57 mm

## Environment

Standards	NSF ANSI 61 EN/IEC 61326-2-3
Product certifications	RCM CE EAC CULus
Ambient air temperature for operation	-30...85 °C
Ambient air temperature for storage	-50...100 °C
Vibration resistance	20 gn (f = 10...2000 Hz) conforming to EN/IEC 60068-2-6
Shock resistance	100 gn for 11 ms conforming to EN/IEC 60068-2-27
IP degree of protection	IP65 conforming to EN/IEC 60529 IP67 conforming to EN/IEC 60529

## Offer Sustainability

Sustainable offer status	Green Premium product
REACH free of SVHC	Yes
EU RoHS Directive	Pro-active compliance (Product out of EU RoHS legal scope) <a href="#">EU RoHS Declaration</a>
Mercury free	Yes
RoHS exemption information	<a href="#">Yes</a>
Environmental Disclosure	<a href="#">Product Environmental Profile</a>
Circularity Profile	No need of specific recycling operations

## Contractual warranty

Warranty	18 months
----------	-----------

Dimensions

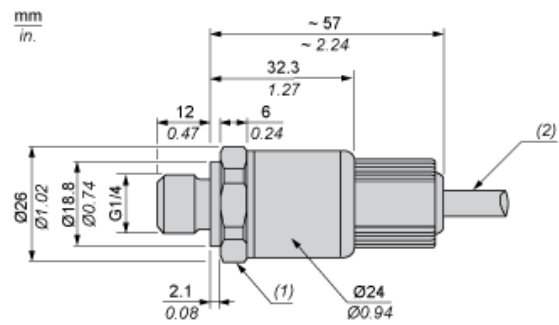

- (1) SW24 tightening torque  $\leq 25$  N.m / 221 lb-in
- (2) Cable

---

Connection and Schema

---

Wiring Diagram

3-Wire Technique (0-10 V)

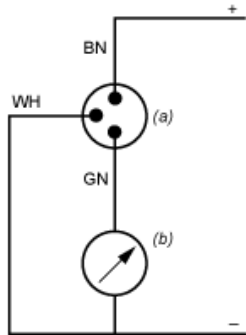

- (a) PVC cable
- (b) V out

---

Performance Curves

---

Curves

