



Price* : 76.74 GBP



Main

Range of product	OsiSense XM
Pressure sensor type	Electromechanical pressure sensor
Pressure sensor name	XMX
Pressure sensor size	25 bar
Contacts type and composition	1 C/O snap action
Controlled fluid	Air (0...70 °C) Fresh water (0...70 °C) Sea water (0...70 °C)
Fluid connection type	4 x G 1/4 (female) conforming to ISO 228
Cable entry	2 entries tapped for Pg 13.5 cable gland conforming to NF C 68-300
Electrical connection	Screw-clamp terminals, clamping capacity: 1 x 1...2 x 2.5 mm ²
Electrical circuit type	Control circuit
[In] rated current	3 A (Ue = 120 V), AC-15, B300 1.5 A (Ue = 240 V), AC-15, B300 0.1 A (Ue = 250 V), DC-13, R300
Setting	Internal
Colour of cover	Black opaque
Pressure switch type of operation	Regulation between 2 thresholds
Scale type	Fixed differential
Local display	Without
Enclosure material	PC impregnated with Lexan 500R
Adjustable range of switching point on rising pressure	3.5...25 bar
Adjustable range of switching point on falling pressure	0.1...20.5 bar
Pressure actuator	Diaphragm
Possible differential minimum at high setting	4.5 bar

Disclaimer: This documentation is not intended as a substitute for and is not to be used for determining suitability or reliability of these products for specific user applications

Possible differential minimum at low setting	3.4 bar
Destruction pressure	100 bar
Materials in contact with fluid	Canvas covered nitrile Chromated zinc alloy
Maximum permissible accidental pressure	56.25 bar

Complementary

Height	126 mm
Width	57 mm
Depth	97.5 mm
Operating position	Any position
Maximum permissible pressure - per cycle	31.25 bar
Short-circuit protection	10 A cartridge fuse, type gG (gl)
Maximum operating rate	10 cyc/mn
[Ui] rated insulation voltage	500 V conforming to EN/IEC 60947-1
[Uimp] rated impulse withstand voltage	EN/IEC 60947-1 6 kV
Electrical durability	1000000 cycles, 50/60 Hz, AC-15, 240 V / 3 A, lth = 10 A
Mechanical durability	1000000 cycles
Repeat accuracy	3.5 %
Product weight	0.65 kg

Environment

Standards	EN/IEC 60947-5-1 CE
Product certifications	UL CSA CCC
Ambient air temperature for operation	-25...70 °C
Ambient air temperature for storage	-40...70 °C
Protective treatment	TC
Electrical shock protection class	Class I conforming to IEC 536
IP degree of protection	IP54 conforming to EN/IEC 60529

Offer Sustainability

Sustainable offer status	Green Premium product
EU RoHS Directive	Pro-active compliance (Product out of EU RoHS legal scope) EU RoHS Declaration
Mercury free	Yes
RoHS exemption information	Yes
Environmental Disclosure	Product Environmental Profile
Circularity Profile	No need of specific recycling operations

Contractual warranty

Warranty	18 months
----------	-----------

Dimensions

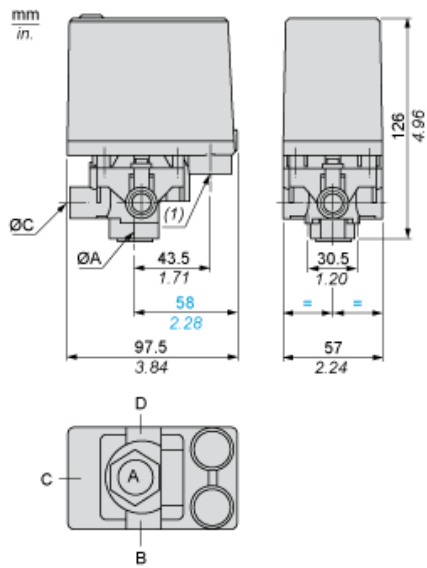

(A = B = C \varnothing D)4 (female)
(1) 2 tapped entries PG 13.5

Minimum Mounting Clearance

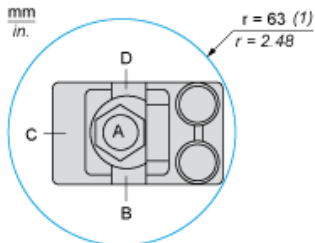

($\varnothing A = \varnothing B = \varnothing C = \varnothing D$)
(1) Minimum clearance zone for screwing-on pressure switch at point A

Wiring Diagram

Connections



Curves

Operating Curves

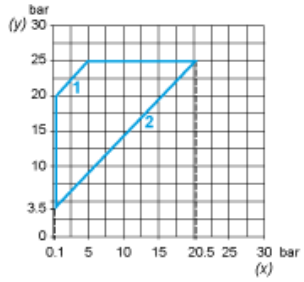

- (y) Rising pressure
- (x) Falling pressure
- 1 : Maximum differential
- 2 : Minimum differential

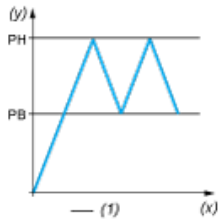

- (y) Pressure
- (x) Time
- (1) Adjustable value