

Price* : 17.03 GBP

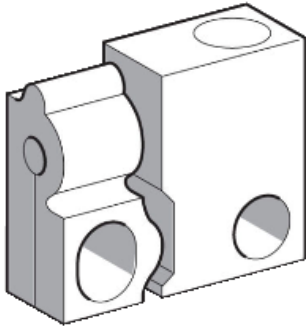

Main

Range of product	OsiSense XU
Accessory / separate part designation	Fixing clamp
Accessory / separate part destination	Plastic fibre optic light guide
Accessory / separate part category	Mounting and fixing accessories
Accessory / separate part type	Fixing clamp
Quantity per set	Set of 2

Complementary

Product compatibility	XUFZ910 XUFZ911 XUFZ921 XUFZ920
Material	Plastic
Line of sight type	Axial
Product weight	0.002 kg

Offer Sustainability

EU RoHS Directive	Pro-active compliance (Product out of EU RoHS legal scope) EU RoHS Declaration
Mercury free	Yes
RoHS exemption information	Yes

Contractual warranty

Warranty	18 months
----------	-----------