

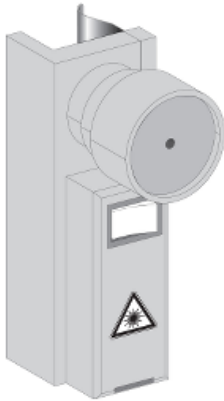

Price\* : 403.05 GBP



## Main

Range of product	Preventa Safety detection
Accessory / separate part designation	Laser alignment tool
Accessory / separate part type	Laser
Accessory / separate part category	Installation accessories
Accessory / separate part destination	Safety light curtain type 4 Safety light curtain type 2

## Complementary

Product weight	0.8 kg
----------------	--------

## Offer Sustainability

Sustainable offer status	Green Premium product
EU RoHS Directive	Pro-active compliance (Product out of EU RoHS legal scope) <a href="#">EU RoHS Declaration</a>
Toxic heavy metal free	Yes
Mercury free	Yes
RoHS exemption information	<a href="#">Yes</a>
Environmental Disclosure	<a href="#">Product Environmental Profile</a>
Circularity Profile	<a href="#">End of Life Information</a>

## Contractual warranty

Warranty	18 months
----------	-----------

## Dimensions

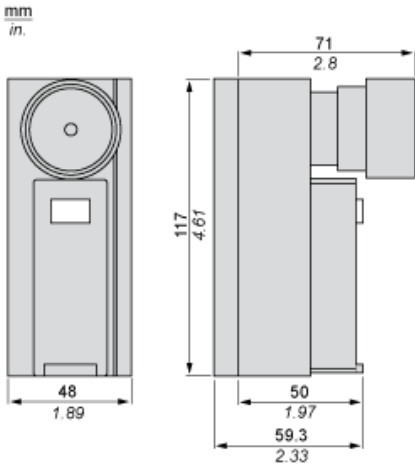

---

Mounting and Clearance

---

Laser Alignment Device

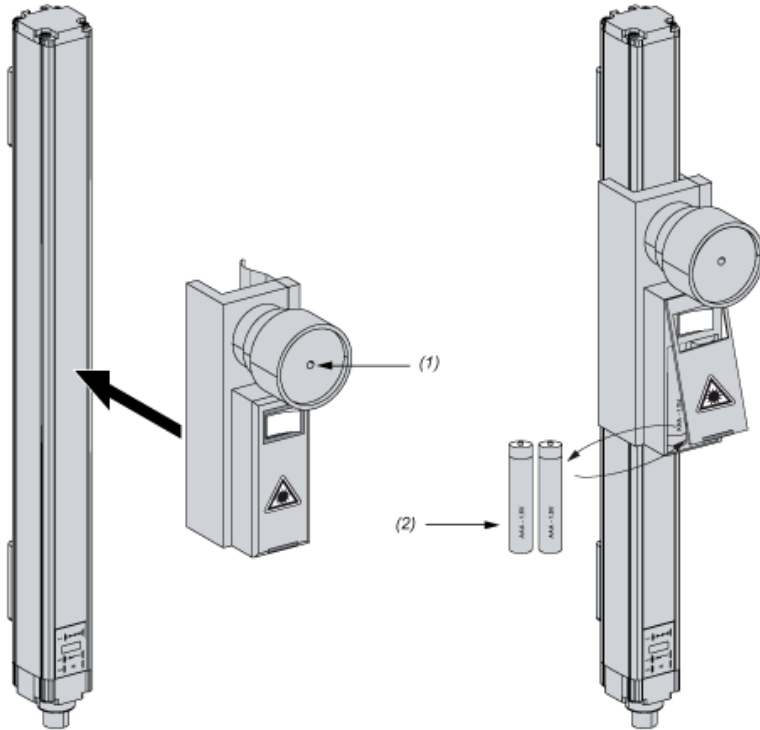

- (1) Position of the laser beam
- (2) 2 AAA batteries (not part of package)