

Main

Range of product	Preventa Safety detection
Accessory / separate part category	Protection accessories
Accessory / separate part type	Protective screen
Product compatibility	XUSL.E...151
Accessory / separate part destination	Safety light curtain type 4 Safety light curtain type 2
Height	1545 mm
Quantity per set	Set of 4

Complementary

Material	Polycarbonate
Sensing distance reduction coefficient	0.97 Sn
Product weight	0.62 kg

Environment

Resistance to chemical agents	Resistant detergents and cleaners Resistant to inorganic diluted acids Resistant alkalis Resistant aqueous solutions
Ambient air temperature for operation	-10...55 °C 14...131 °F
Ambient air temperature for storage	-13...158 °F -25...70 °C

Offer Sustainability

Sustainable offer status	Green Premium product
EU RoHS Directive	Pro-active compliance (Product out of EU RoHS legal scope) EU RoHS Declaration
Toxic heavy metal free	Yes

Mercury free	Yes
RoHS exemption information	Yes
Environmental Disclosure	Product Environmental Profile
Circularity Profile	End of Life Information

Contractual warranty

Warranty	18 months
----------	-----------

Mounting and Clearance

Various Stages in the Protective Screen Assembly

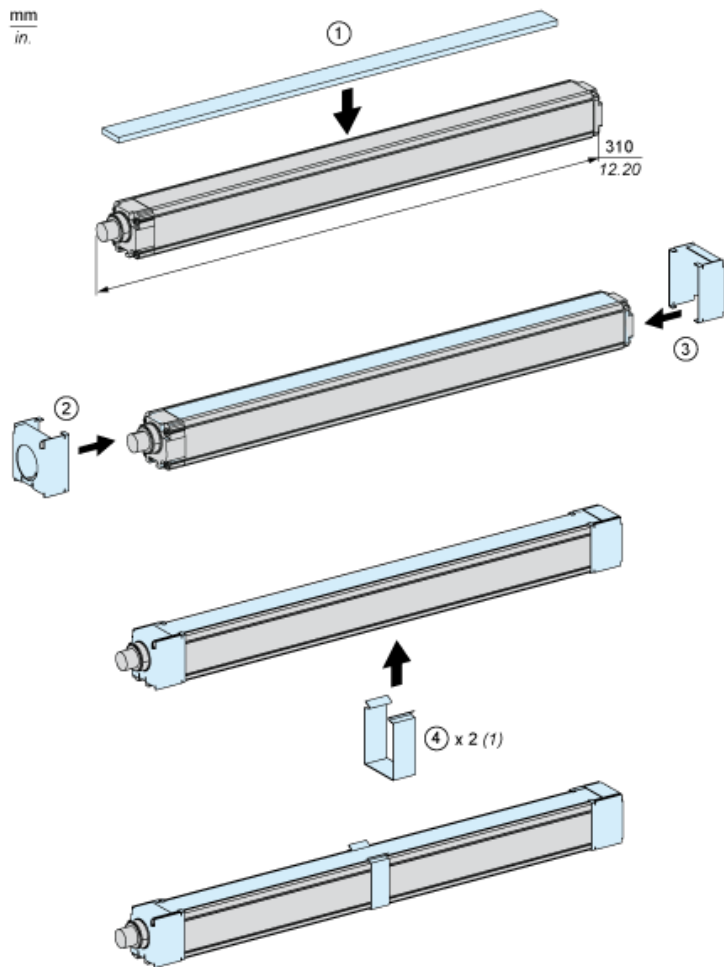

(1) Depending on the length