

Main

Range of product	Preventa Safety detection
Accessory / separate part category	Mounting and fixing accessories
Accessory / separate part type	Fixing accessory
Product compatibility	XUSZWPE...
Accessory / separate part destination	Protective cover

Complementary

Ambient air temperature for operation	-30...55 °C -22...131 °F
Ambient air temperature for storage	-30...70 °C -22...158 °F
Kit composition	4 x stainless steel fixation clamp(s) 4 x stainless steel end clamp(s)
Product weight	0.15 kg

Offer Sustainability

Sustainable offer status	Green Premium product
EU RoHS Directive	Pro-active compliance (Product out of EU RoHS legal scope) EU RoHS Declaration
Toxic heavy metal free	Yes
Mercury free	Yes
RoHS exemption information	Yes
Environmental Disclosure	Product Environmental Profile
Circularity Profile	End of Life Information

Contractual warranty

Warranty	18 months
----------	-----------

Mounting and Clearance

Various Stages in the Protective Screen Assembly

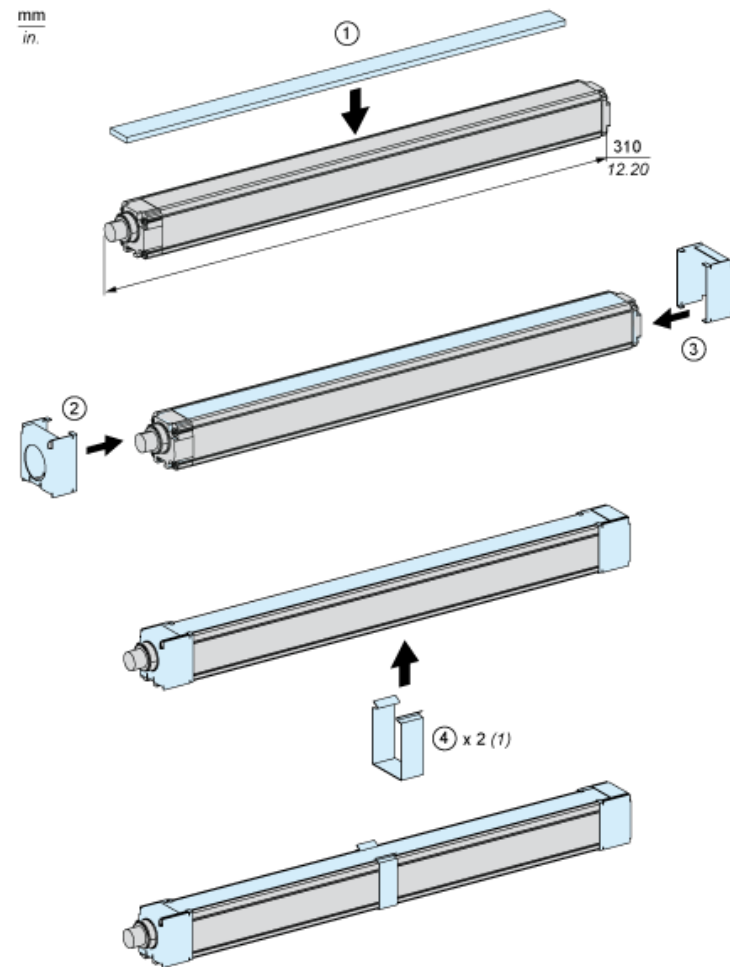

(1) Depending on the length